

MOTOR BLOCK PMDH / PMF 250

Parts list	Code	List \$ Price
Motor brushes (2)	0514	15,31
Ball bearing	0601	15,31
Squeezing washer	0726	2,15
Wall bracket	0880	8,94
Non-locking switch	0908	32,06
Capacitor	0909	13,58
Strain relief 230 V	0950	2,68
Strain relief 115V	0950.1	2,68
Warning label	1017	5,39
Dynamic label	1027	13,35
Label w/ serial number 230 V	1071	5,60
Label w/ serial number 115 V	1072	5,60
Variable speed control board 230 V	1213	106,11
Variable speed control board 115 V	1214	92,21
Spacer screws (4)	7903	4,96
Spacer rods (4)	7913.F	17,26
Variable speed control knob	8609	14,92
Power cord 230 V	9011	23,76
Stator screws (2)	9023	4,04
Self-lubricating ring	9025	4,68
Coupler for armature	9028	10,19
Power cord 115 V	9040	29,74
Power cord (UK)	9067	54,21
Handle screws (3)	9502	0,66
Switch protector	9813	9,25
Upper motor casing	9817	47,75
Fan	9818	11,01
Rotor w/o coupling 230 V	9819	258,38
Rotor w/o coupling 115 V	9819.1	258,38
Stator 230 V w/carter, carbon brushes holders	9820	258,38
Stator 115 V w/carter, carbon brushes holders	9820.1	258,38
Upper half handle	9832	28,02
Complete handle 230 V	9840	135,51
Complete handle 115 V	9840.1	135,51
Lower half handle w/ label 230 V	9841	31,19
Lower half handle w/ label 115 V	9841.1	31,19
Aluminium carter	9842	143,67
BM 250 Motor block (see machine catalog)	AC005	-

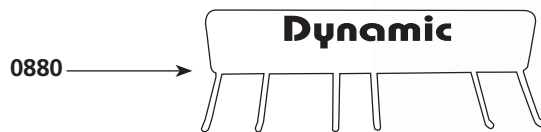

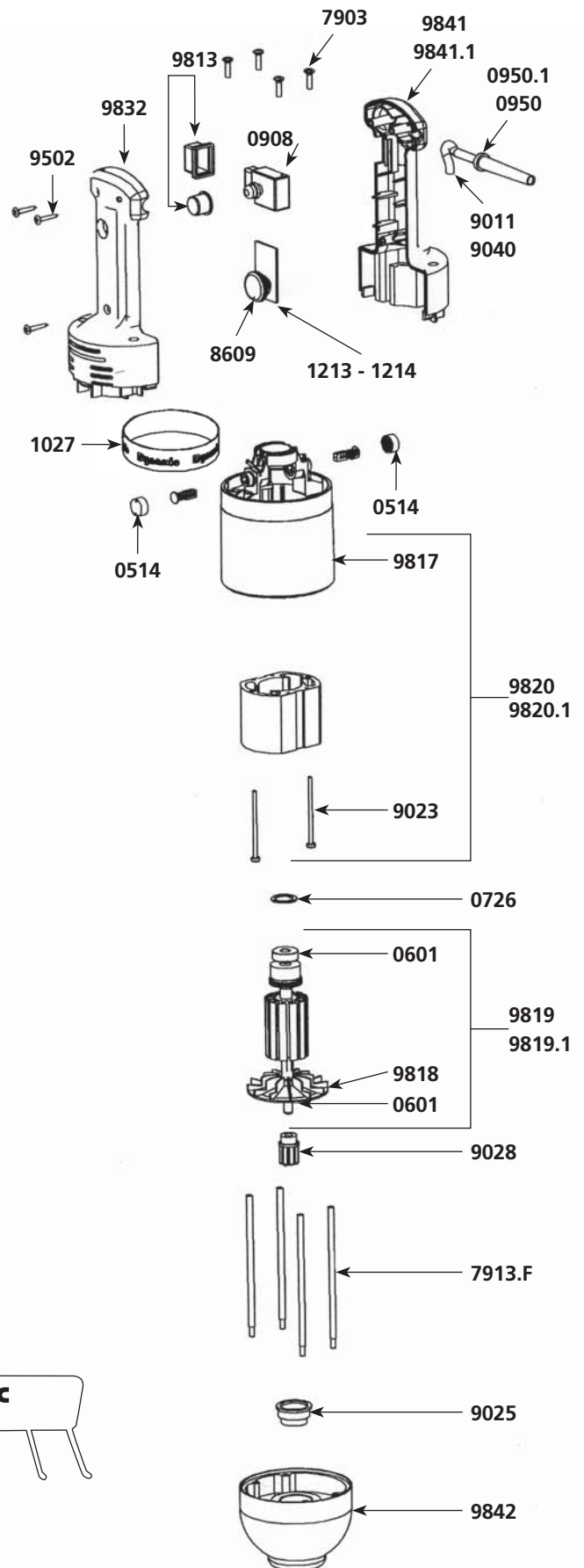
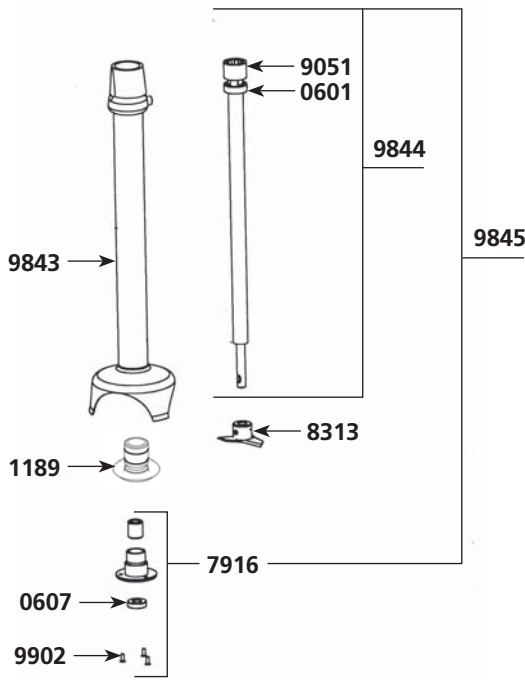

PMF - PMDH 250 foot

Parts list	Code	List \$ Price
Ball bearing	0601	15,31
Waterproof seal	0607	19,97
Lower bearing assembly support	1189	22,89
Lower ball bearing assembly	7916	37,10
Cutter blade (w/screw)	8313	40,54
Coupling casing + pins	9051	16,18
Tube assembly + palier + bearing	9843	135,51
Shaft & coupling sleeve	9844	173,51
Shaft, lower bearing & cutter assembly	9845	156,21
Lower bearing screws (3)	9902	1,34
M 250 Complete Mixer tool (see machine catalog)	AC006	-

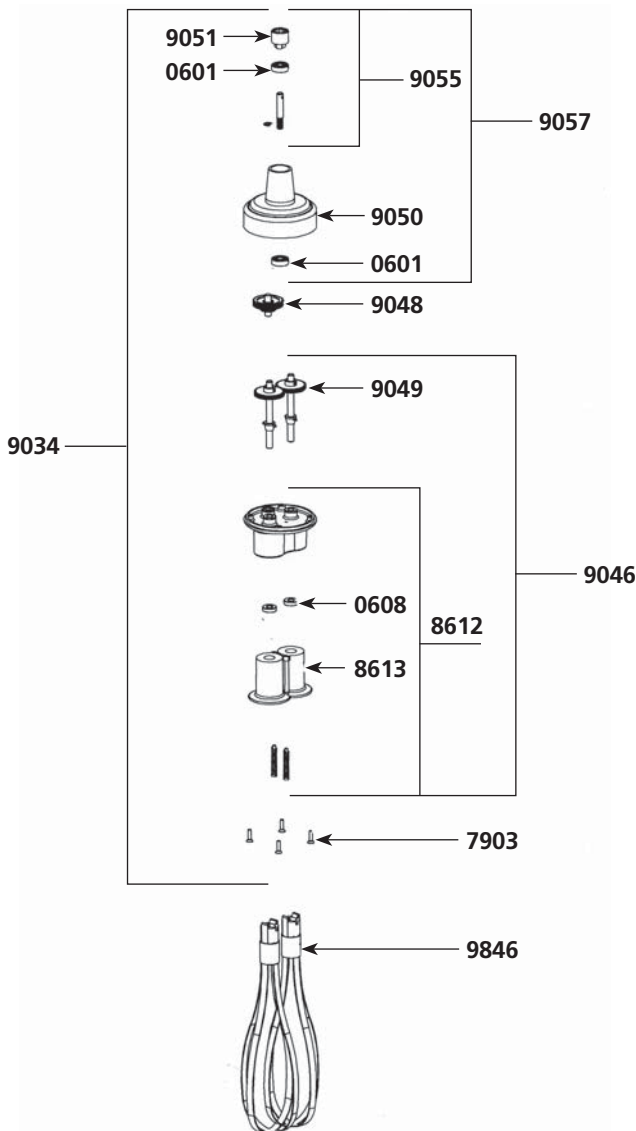

PMF 250 whisk tools

Parts list	Code	List \$ Price
Ball bearing	0601	15,31
Waterproof seal for whisk	0608	20,54
Pin 3 X 20	0744	2,38
Pin 3 X 14	0745	2,15
Spacer screws (4)	7903	4,96
Holder + plastic ejector + seal	8612	69,80
Plastic ejectors (pair)	8613	29,80
Reduction gear assembly	9034	315,97
Lower casing w/o middle gear	9046	261,98
Central double gear & shaft	9048	111,17
Single gear (2) + pin	9049	90,37
Upper plastic casing	9050	92,21
Coupling casing + pin	9051	16,18
Equipped upper shaft	9055	76,80
Complete upper casing	9057	119,82
Whisks (2)	9846	151,87
F 250 Complete Whisk tool (see machine catalog)	AC007	-