

## Power unit

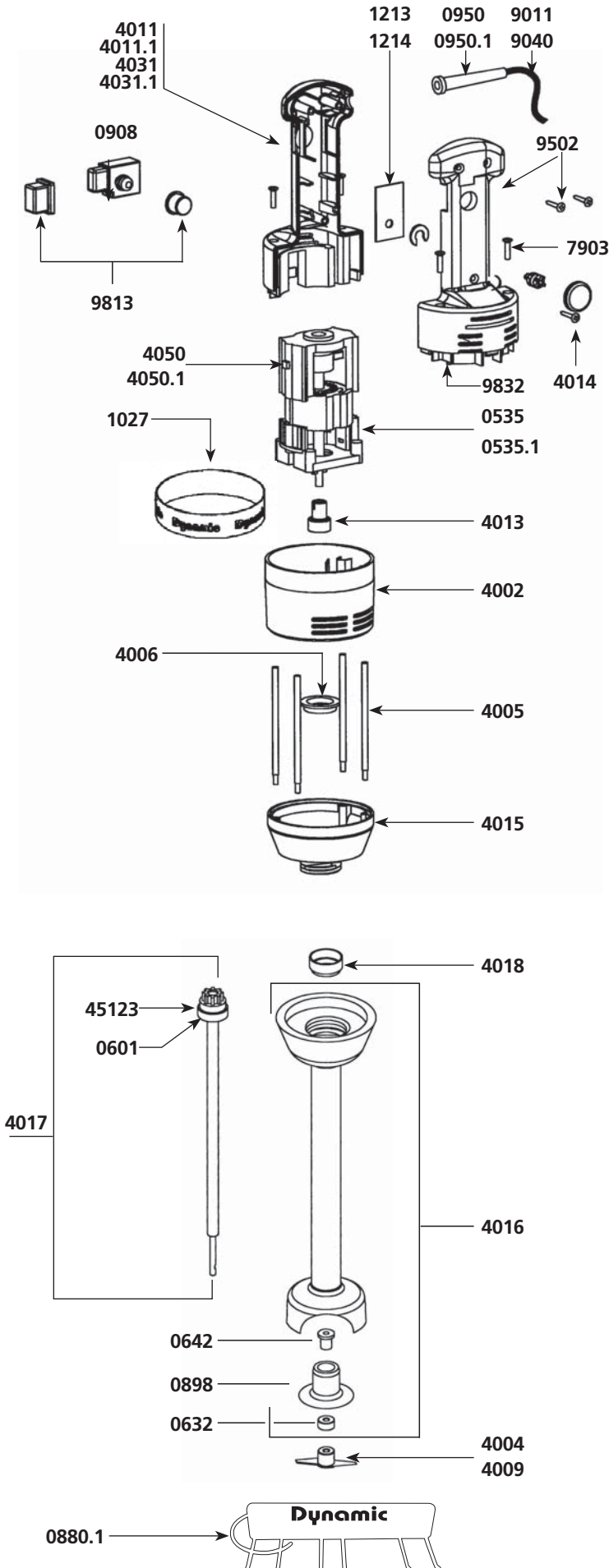

### Parts list

Code List \$ Price

Stator 230 V	0535	181,98
Stator 115 V	0535.1	181,98
Wall bracket	0880.1	79,16
Non-locking switch	0908	32,06
Strain relief 230V	0950	2,68
Strain relief 115V	0950.1	2,68
Dynamic label	1027	13,35
Id label (Junior Plus) 230V	1084	5,75
Id label (Junior Plus) 115V	1085	5,75
Id label (Junior Combi) 230V	1086	5,75
Id label (Junior Combi) 115V	1087	5,75
Speed variator 230V	1213	106,11
Speed variator 115V	1214	92,21
Upper motor housing	4002	26,19
Spacer rods (4)	4005	16,92
Ball bearing sleeve	4006	4,81
Complete handle w/ power cord 230V	4010	115,99
Complete handle w/ power cord 115V	4010.1	115,99
Lower half handle w/ Junior Plus label 230V	4011	31,19
Lower half handle w/ Junior Plus label 115V	4011.1	31,19
Filtering capacitor	4012	18,67
Coupling	4013	14,37
Speed variator knob	4014	14,37
Lower aluminium motor housing	4015	124,52
Complete handle w/ power cord 230V	4030	115,99
Complete handle w/ power cord 115V	4030.1	115,99
Lower half handle w/ Junior Combi label 230V	4031	31,19
Lower half handle w/ Junior Combi label 115V	4031.1	31,19
Motor brushes (2) 230 V	4050	13,41
Motor brushes (2) 115 V	4050.1	13,41
Spacer screws (4)	7903	4,96
Power cord 230 V	9011	23,76
Power cord 115 V	9040	29,74
Power cord (Australian)	9066	59,58
Power cord (UK)	9067	54,21
Handle screws (3)	9502	0,66
Switch protector	9813	9,25
Upper half handle Junior Plus & Junior Combi	9832	28,02
Complete motor block (see machine catalog)	AC100	-

## Complete foot assembly

### Parts list

Code List \$ Price

Ball bearing	0601	15,31
Waterproof seal	0632	9,30
Bushing	0642	2,06
Bearing only	0898	17,71
Cutter blade	4004	31,45
Emulsifying blade	4009	44,56
Foot assembly	4016	199,57
Kit w/shaft and coupling hub	4017	86,23
Ball bearing sleeve	4018	4,33
Coupling hub	45123	24,19
Complete Junior foot (see machine catalog)	AC101	-

0880.1

**Dynamic**