

PROFESSIONNAL SERIE

TABLE TOP VEGETABLE SLICER, FOOD PROCESSOR AND BLEND & MIX

3 in 1



A NEW DYNAMIC[®] WAY TO PREPARE FOOD !



www.dynamicmixers.com



- UNTIL 300 KG PER HOUR
- SUITABLE FOR 400 COVERS PER SERVICE

3 in 1

COMBINED 3-in-1

TABLE TOP ELECTRIC VEGETABLE SLICER, FOOD PROCESSOR AND BLEND & MIX

- PERFECT HYGIENE
- DISHWASHER PROOF
- HANDLE EASY CLIP
- QUICK TOOL FREE ASSEMBLY AND DISASSEMBLY
- POWERFUL ASYNCHRONOUS MOTOR FOR INTENSIVE USE



Cylindrical hopper for more precision (zucchini, cucumber ...)

Large hopper for more productivity and bulky vegetables (cabbage & celery)

Space saving, side ejection



REGISTERED MODEL

DELIVERED WITH STANDARD KNIFE



CAPACITY : 5.4 LITRES

Excellent stability, metal engine base

	Designation COMBINED VARIABLE SPEED control panel	Designation COMBINED SCREEN VARIABLE SPEED digital display screen
Vegetable Slicer Speed R.P.M.	320 to 720 R.P.M.	320 to 720 R.P.M.
Food Processor Speed R.P.M.	350 to 3500 R.P.M.	350 to 3500 R.P.M.
Functions	Pulse & Reverse	Pulse, reverse*, countdown timer*, timer*
Output	1100 W	1100 W
Item code	CL322	CL350

* Food processor only

✓ **STAINLESS STEEL & METAL MOTOR BASE**

VEGETABLE SLICER



	Designation VEGETABLE SLICER 1 SPEED control panel	Designation VEGETABLE SLICER 2 SPEEDS control panel	Designation VEGETABLE SLICER VARIABLE SPEED control panel	Designation VEGETABLE SLICER SCREEN VARIABLE SPEED digital display screen
Speed R.P.M.	320 R.P.M.	320 and 640 R.P.M.	320 to 720 R.P.M.	320 to 720 R.P.M.
Functions	-	-	Pulse	Pulse
Speed	1 speed	2 speeds	5 levels	5 levels
Output	1100 W	1100 W	1100 W	1100 W
Item code	CL100	CL110	CL121	CL150

— **CONVERTIBLE INTO A FOOD PROCESSOR AND BLEND&MIX** —



REGISTERED MODEL

DELIVERED WITH STANDARD KNIFE





The largest **stainless steel** discs on the market, diameter 225 mm. Dishwasher safe.

ACCESSORIES

Accessories available separately.



High precision and removable blade for re-sharpening



Slicing disc

	Item Code
0,5 mm	CL1005
1,5 mm	CL1015
2,5 mm	CL1025
3 mm	CL1030
4 mm	CL1040
5 mm	CL1050
7 mm	CL1070
8 mm	CL1080
9 mm	CL1090
11 mm	CL1110
12 mm	CL1120
13 mm	CL1130

“ Make many preparations thanks to a complete range of discs! ”

COMPLETE VEGETABLE SLICER KIT

Cover, pusher handle, tray



Item Code

CL9000

COMPLETE FOOD PROCESSOR KIT

Bowl, lid, smooth blade



Item Code

CL9001

DISC SUPPORT

Adjustable unit table or wall disc support

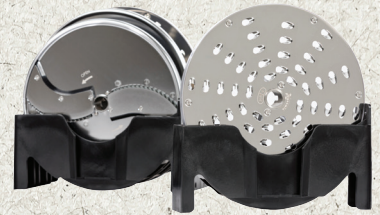

Item Code

CL7000



Grating disc

	Item Code
2 mm	CL2002
3 mm	CL2003
5 mm	CL2005
9 mm	CL2009



Julienne disc

	Item Code
3X2 mm	CL3032
4X2 mm	CL3042
4X4 mm	CL3044
5X5 mm	CL3055
5X2 mm	CL3052
8X8 mm	CL3088
10X10 mm	CL3010

FRONT

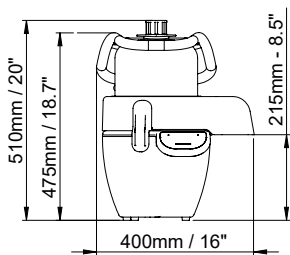

SIDE

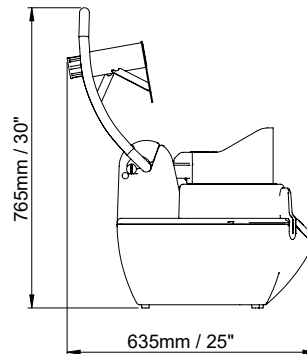
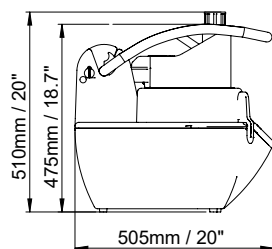

TOP

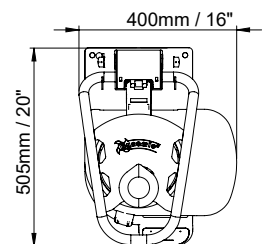

- FROM 100G TO 4KG
- SUITABLE FOR 20 TO 100 COVERS PER SERVICE

TABLE TOP FOOD PROCESSOR

MIX, EMULSIFYING, BLENDING AND CHOPPING IN A FEW SECONDS

CAPACITY : 5.4 LITRES



DELIVERED WITH STANDARD KNIFE



Scraper

Fully removable lid for better hygiene

Seal for waterproofness

Stainless steel food processor bowl

Timer and countdown functions available

Designation
FOOD PROCESSOR 1 SPEED
control panel

Designation
FOOD PROCESSOR 2 SPEEDS
control panel

Designation
FOOD PROCESSOR VARIABLE SPEED
control panel

Designation
FOOD PROCESSOR SCREEN VARIABLE SPEED
digital display screen

Speed R.P.M.	1500 R.P.M.	1500 and 3000 R.P.M.	350 to 3500 R.P.M.	350 to 3500 R.P.M.
Functions	-	Pulse & Reverse	Pulse & Reverse	Pulse & Reverse, countdown timer & timer
Speed	1 speed	2 speeds	10 levels	10 levels
Output	1100 W	1100 W	1100 W	1100 W
Item code	CL200	CL212	CL222	CL250

CONVERTIBLE INTO A VEGETABLE SLICER AND BLEND&MIX

ACCESSORIES



Smooth knife



To prepare fine stuffing and mousselines, minced meats, sauces, emulsions, butters, duxelles, smooth and modified textures on baked products.



Serrated knife



To smooth pasta, knead, grind, make pralines, mix spices.



Micro-serrated knife



To chop herbs, smooth and modified textures on raw products.

FRONT

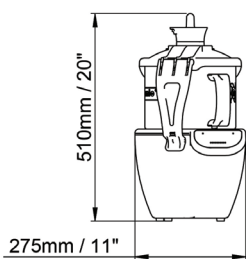

SIDE

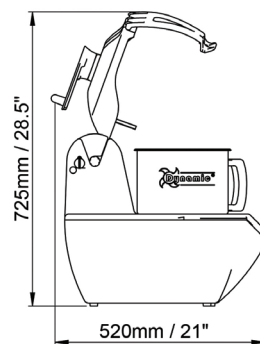
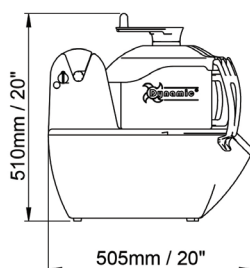

TOP

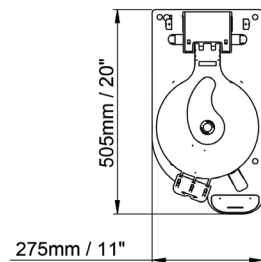

BLEND & MIX

FUNCTION 2-IN-1

IDEAL FOR SOFT DIET PREPARATIONS



DELIVERED WITH A STANDARD BLADE AND A MICRO-SERRATED BLADE



CAPACITY : 5.4 LITRES

	Designation BLEND & MIX 2 SPEEDS control panel	Designation BLEND & MIX VARIABLE SPEED control panel	Designation BLEND & MIX SCREEN VARIABLE SPEED digital display screen
Speed R.P.M.	1500 and 3500 R.P.M.	350 to 3500 R.P.M.	350 to 3500 R.P.M.
Functions	Pulse & Reverse	Pulse & Reverse	Pulse & Reverse, countdown timer & timer
Speed	2 speeds	10 levels	10 levels
Output	1100 W	1100 W	1100 W
Item code	CL412	CL422	CL450

CONVERTIBLE INTO A VEGETABLE SLICER AND FOOD PROCESSOR



“The essential tool for smooth and modified structure preparations, raw or cooked.”

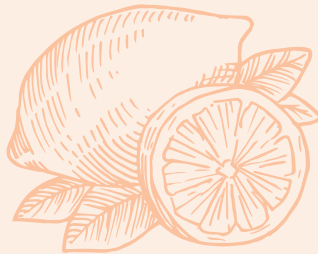

The BLEND&MIX keeps all the nutritional and taste qualities of the food intact, as well as the organoleptic properties.

People suffering from chewing problems can keep the pleasure of enjoying a varied and tasty diet.

The Blend & Mix from Dynamic is the essential partner for collective kitchens (nursing homes, hospitals, schools, etc...) !

The finger-food

This presentation of plates is based on the texture modification of the food to make into bite-sized pieces so that people can feed themselves with their hands.

In health establishments, this mode of feeding is implemented when a person has gripping and/or coordination difficulties.

The interest of the finger-food lies in the preservation of autonomy, prevents undernutrition, limits behavioural problems, promotes self-confidence and allows to find the pleasure of eating again.



Healthy food is a must!

The trend is towards a plant-based, natural and sustainable offer, increasingly diversified to meet the expectations of healthy meals and snacks.

All this requires versatile, robust and easy to maintain equipment. The Combined, Food processor / Vegetable slicer / Blend&mix allows you to cut various fruit and vegetables in the cutting version or to chop, grind, emulsify or knead in the food processor version. Easily interchangeable, this 3-in-1 is evolving according to your needs.



THE ESSENTIALS

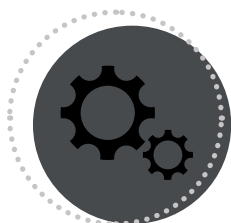

MAINTENANCE

All accessories are dishwasher proof. Patented quick assembly and disassembly without tools for accessory replacement and cleaning.



ERGONOMY

Ergonomic and intuitive design for ease of use. Integrated handle for transporting the device. Easy to handle, suitable for both right and left handed users. Instant and intuitive placement of the receptacle and accessories.



COMFORT

Incredibly quiet 50 Db and vibration free motor (reduces noise in the kitchen).

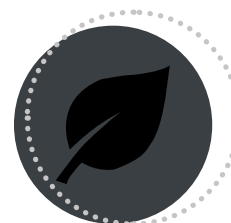

SUSTAINABILITY

Choice of raw materials to ensure longevity and reduce waste. More than 90% of the components are recyclable.

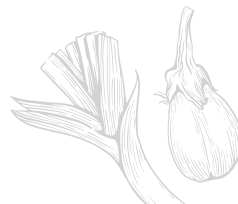

DYNAMIC FRANCE

518 rue Léo Baekeland - BP57 - 85290 Mortagne / Sèvre - FRANCE
Tel. 02 51 63 02 72 / E-mail : export@dynamicmixers.com
www.dynamicmixers.com

